

[Home](#) → [Spec Search](#) → [All Types](#) → [Mini Excavator](#) → [Kubota](#) → KX71-3

KUBOTA KX71-3 MINI EXCAVATOR

[VIEW ARTICLES ON THIS ITEM](#)

Print specification

Looking to purchase this item?

[Find a Kubota KX71-3 Mini Excavator](#) being sold at Ritchie Bros. auctions.

Need to sell equipment?

[Complete this form](#) and a Ritchie Bros. representative will contact you.

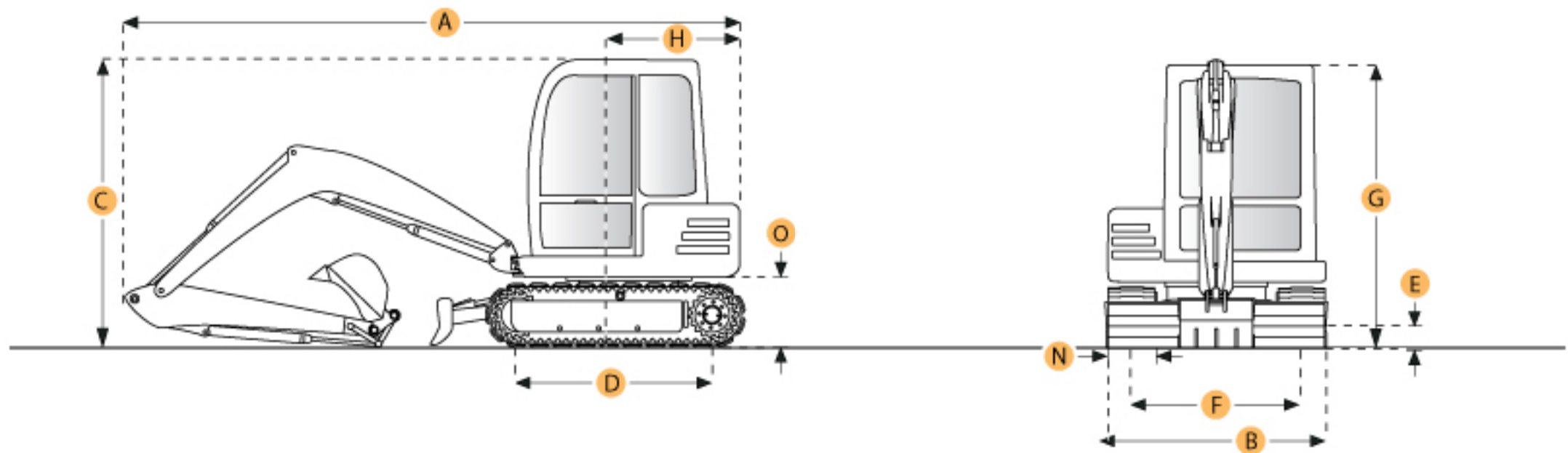

Selected Dimensions

Boom/Stick Option (HEX) 1

A. SHIPPING LENGTH OF UNIT	14.9 ft in	4550 mm
C. SHIPPING HEIGHT OF UNIT	8 ft in	2430 mm
I. MAX CUTTING HEIGHT	15.4 ft in	4700 mm
J. MAX LOADING HEIGHT	10.4 ft in	3180 mm
K. MAX REACH ALONG GROUND	16 ft in	4880 mm
L. MAX VERTICAL WALL DIGGING DEPTH	6.4 ft in	1950 mm
M. MAX DIGGING DEPTH	9.7 ft in	2970 mm

Dimensions

B. WIDTH TO OUTSIDE OF TRACKS	4.9 ft in	1500 mm
D. LENGTH OF TRACK ON GROUND	ft in	mm
E. GROUND CLEARANCE	1 ft in	305 mm
G. HEIGHT TO TOP OF CAB	ft in	mm
H. TAIL SWING RADIUS	4 ft in	1210 mm

Specification

Engine

MAKE	Kubota	
MODEL	V1505	
GROSS POWER	27.5 hp	20.5 kw
DISPLACEMENT	91.4 cu in	1.5 L
NUMBER OF CYLINDERS	4	
ASPIRATION	liquid-cooled, overhead valve diesel engine	

Operational

OPERATING WEIGHT	6305 lb	2859.9 kg
FUEL CAPACITY	11.9 gal	45 L
COOLING SYSTEM FLUID CAPACITY	1.4 gal	5.3 L
HYDRAULIC SYSTEM FLUID CAPACITY	13.2 gal	50 L
ENGINE OIL CAPACITY	1.2 gal	4.5 L
HYDRAULIC PUMP FLOW CAPACITY	17 gal/min	64.4 L/min

Swing Mechanism

SWING SPEED	9.4 rpm
-------------	---------

Undercarriage

GROUND PRESSURE	3.9 psi	26.9 kPa
MAX TRAVEL SPEED	2.8 mph	4.5 km/h

Boom/Stick Option (HEX) 1

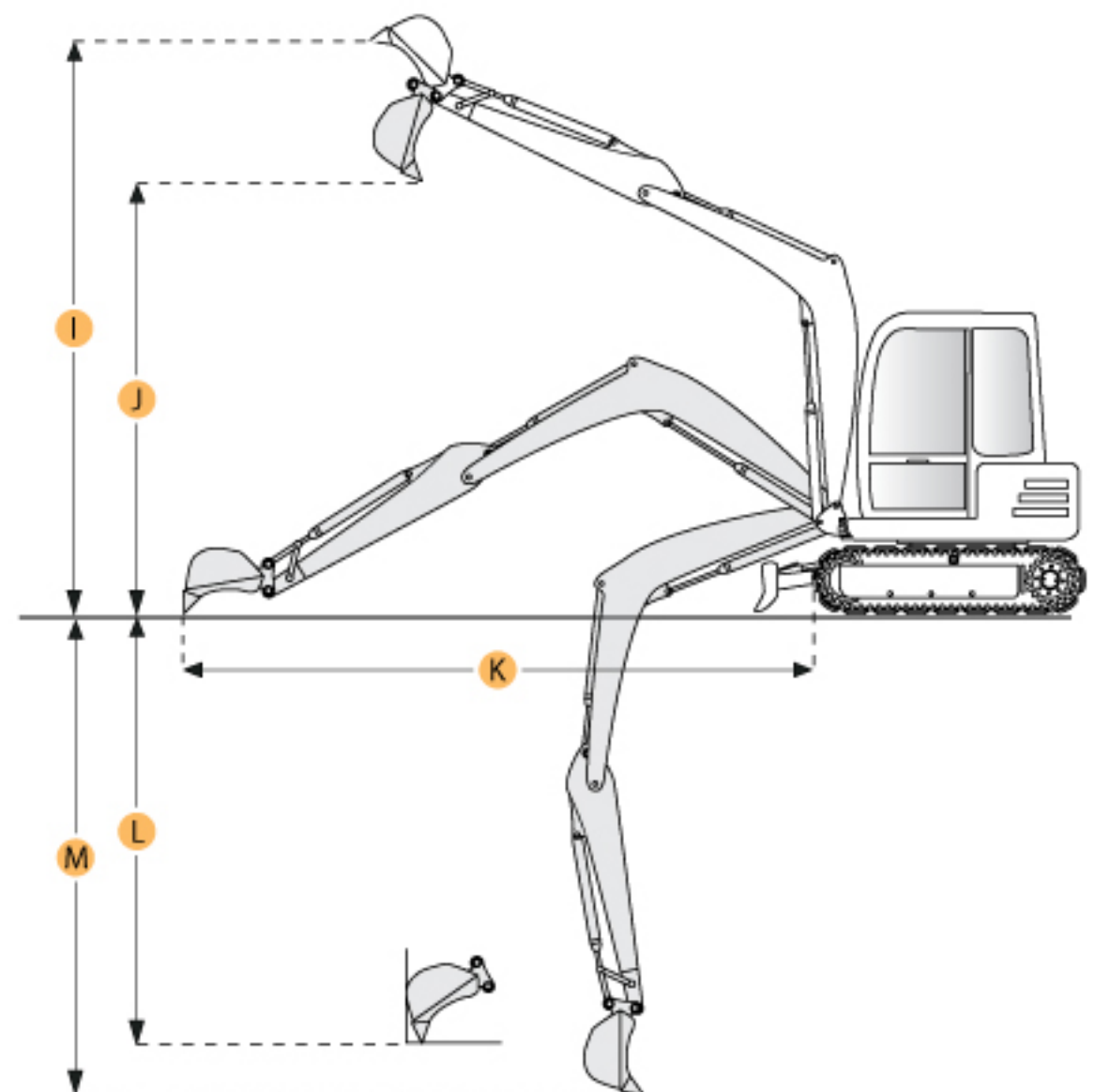

SHIPPING HEIGHT OF UNIT	8 ft in	2430 mm
SHIPPING LENGTH OF UNIT	14.9 ft in	4550 mm
MAX DIGGING DEPTH	9.7 ft in	2970 mm
MAX REACH ALONG GROUND	16 ft in	4880 mm
MAX CUTTING HEIGHT	15.4 ft in	4700 mm
MAX LOADING HEIGHT	10.4 ft in	3180 mm
MAX VERTICAL WALL DIGGING DEPTH	6.4 ft in	1950 mm

Dimensions

WIDTH TO OUTSIDE OF TRACKS	4.9 ft in	1500 mm
HEIGHT TO TOP OF CAB	ft in	mm
GROUND CLEARANCE	1 ft in	305 mm
TAIL SWING RADIUS	4 ft in	1210 mm
LENGTH OF TRACK ON GROUND	ft in	mm

© 2007-2017 RitchieSpecs Equipment Specifications Ritchie Bros. Auctioneers © | [Terms of Use](#) | [Privacy Statement](#)
 OEM specifications are provided for base units. Actual equipment might vary with options.